

KidCo is a member of:



Made in Denmark for:
KidCo, Inc.
1013 Technology Way
Libertyville, IL 60048

www.kidco.com
Phone 800-553-5529
Fax 800-553-0221





Patent:
5,890,320



Shown with 5 Optional 24" sections

User Guide

ConfigureGate® Model G80

Optional 8" section (G80-8) or 24" section (G80-24)
available for larger areas.

KidCo, Inc

Important Notes

FOLLOW THESE INSTRUCTIONS CAREFULLY AND KEEP THEM FOR FUTURE REFERENCE

Before attempting to unfold the gate, read instructions thoroughly. Failure to do so may result in damage to the gate or injury to your child.

Your ConfigureGate™ is completely assembled and folded compactly and must be unfolded in sequence. Unpack your ConfigureGate™ onto a stable surface. Familiarize yourself with the parts by comparing them to the parts check list below.

WARNING

- Intended for use with children from 6 months through 36 months.
- Check the stability of the gate and tighten all hardware and mountings regularly.
- To prevent serious injury or death, securely install gate or enclosure and use according to manufacturer's instructions.
- Never use with a child able to climb over or dislodge/open the gate or enclosure.
- Never use if gate is 3/4 child's height.
- Do not use if any part of gate is broken or missing.
- This product will not necessarily prevent all accidents. Never leave child unattended.
- Use only spare parts from KidCo.
- Never allow child to climb or swing on gate.
- Use only with the locking/latching mechanism securely engaged.
- Closely supervise child when gate is installed at the top of the stairs.
- Discontinue use if any part of gate is damaged.
- Never climb over gate.
- Never hang or tie toys etc. to any part of the gate.

Parts Check List



Standard ConfigureGate™ has three 24" sections including a walk through door



2 Wall Plates (C)



2 Wall Covers (A)



6 Screws for mounting directly into wood (D)



6 Screws for Wall Covers (E)



6 Nuts for Wall Covers (F)



2 Plastic Hinge Covers (G)
(shipped assembled on top of bottom hinge of end sections)



2 Plastic Hinge Caps (H)
(shipped assembled on top of cone hinge of end sections)



2 Lock Fittings (B)



2 Removable Cones (I)
(use only when a section is removed - and always place under top hinge of gate).

Unpacking

1.



Unpack your folded ConfigureGate™ on a stable surface, making sure handle is on top. Each corner is connected by plastic, interlocking hinges.

2.

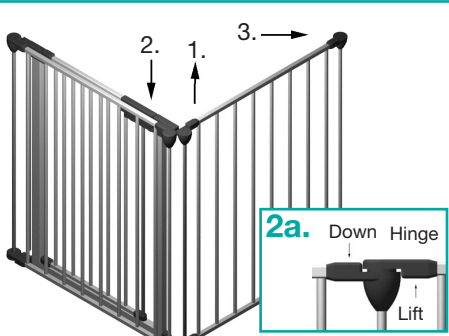

How to adjust sections:

A spring is fitted in all cones which deliberately creates tension when adjusting. At corner, lift up slightly on section with hinge teeth facing down (1) while gently pressing down on connected section (2). Rotate sections to desired position. (3). Release to lock into place.

Note: Each hinge adjusts from 0° to 270° in 10° increments.

3.

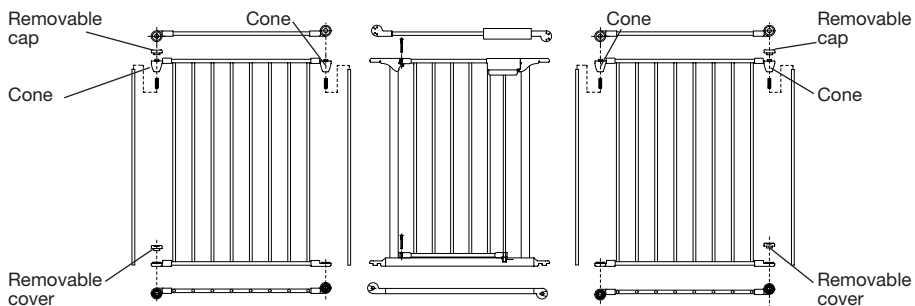

4.

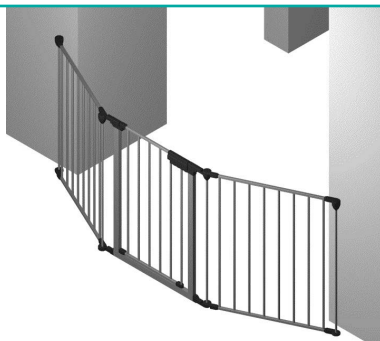

Position the ConfigureGate™ to the desired shape. It may be necessary to remove or add section/s to the gate to fit your application.

If making no changes, see "Installation" steps 12 to 22.

If removing sections, see "Assembly" steps 5 to 9.

If adding sections, see "Assembly" steps 5 to 7.

Assembly



Removing or adding sections:

Note: Always begin separating the gate from either end. At the juncture of every section is a removable, vertical bar.

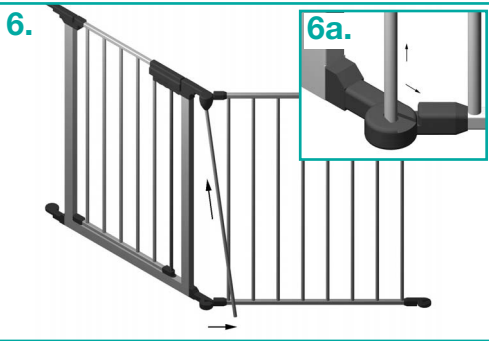

To remove vertical bar, lift up on bar (5), while sliding it out of lower hinge groove (6a.). Pull bar down and out of cone (6.).



Lift off end section. If gate is now appropriate length, go to step 8.

If additional section/s are required, go to steps 10 & 11.

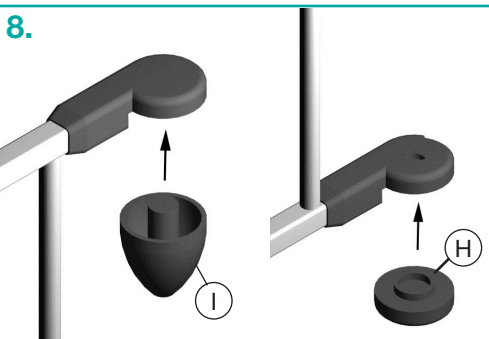

Remove hinge cap (H) from top hinge of original end section. A screwdriver may be needed to pry it off. Place under bottom hinge. Install removable cone (I) under top hinge of new end section.

Assembly

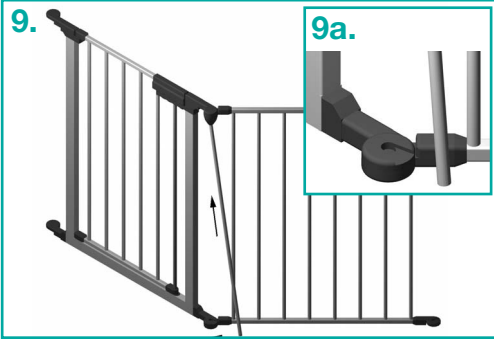

Reinstall a removable, vertical bar. Insert bar by pressing it into upper hinge cone, while sliding bar into groove of lower hinge. Spring in cone will make bar lock in place. Proceed to "Installation" steps 12 to 22.

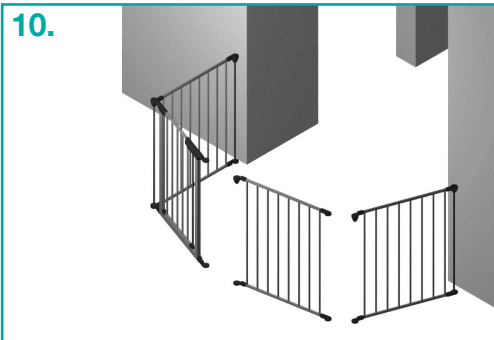

Adding optional section/s:

Remove vertical bar from optional section (steps 5 & 6).

Position optional section with cone hinge at top. Align cone hinge underneath top hinge on end section. When center of both hinges are aligned, top and bottom, they will fall together.

Insert removable bar (see step 9).

If adding more than one section, repeat process.



Reattaching the end sections:

Align top cone corner of one section with top hinge of the end section. When center of both hinges are aligned, top and bottom, they will fall together.

Insert removable bar.

Proceed to "Installation" steps 12 to 22.

Note: The ConfigureGate™ cannot be completely folded when optional section/s have been added.

Relocating the walk through door section:

The walk through door section can be repositioned in the configuration as long as it is interchanged with a section that has matching top and bottom hinges (refer to diagram 3).

Installation

12.

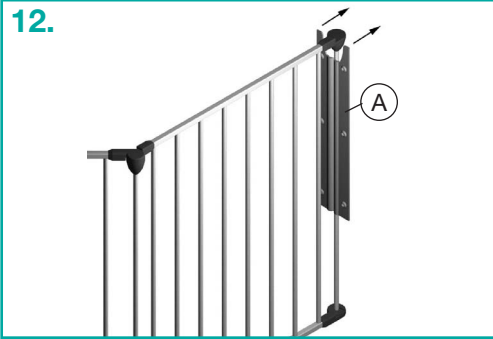

Installing the wall mountings:

Fold wall cover (A) around vertical bar at end of gate.

13.

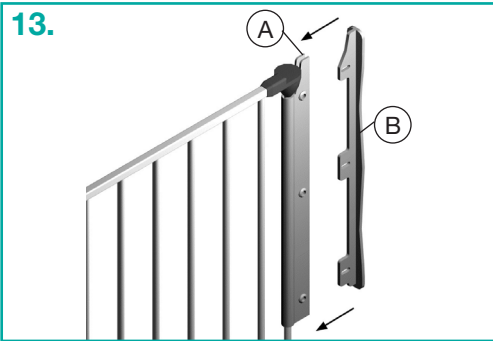

Insert lock fitting (B).

14.

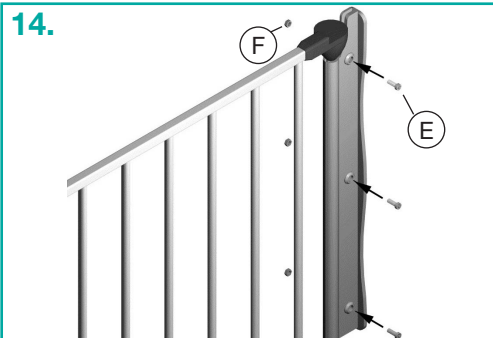

Insert 3 wall cover screws (E) through oblong holes in top, middle and bottom of the assembly.

Note: Loosely screw on nuts (F), **but do not tighten at this time.**

15.

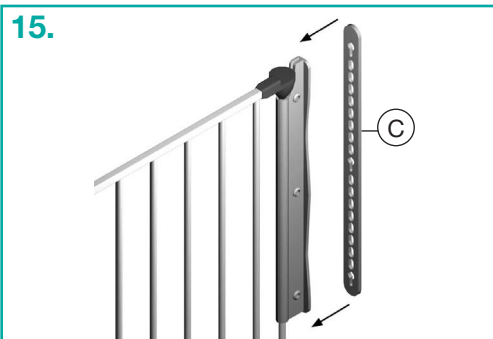

Fasten wall plate (C) onto assembly. See steps 16. a, b and c.

Installation

16.

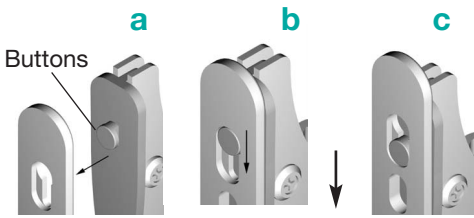

Center buttons of assembly with wall plate holes (a). When aligned, push buttons through holes and slide down to lock (b & c).

17.



Now it should look like this.

18.

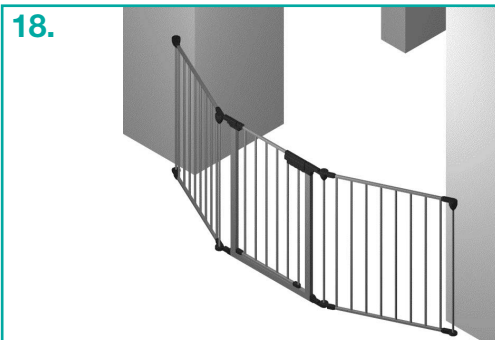

Move ConfigureGate™ to desired location.

19.

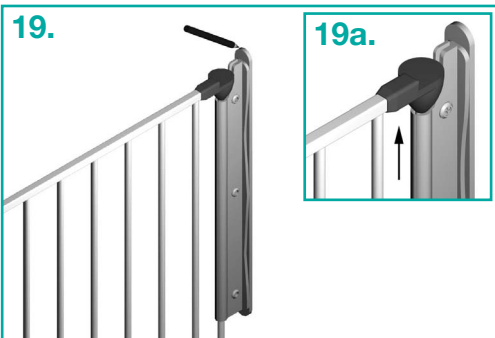

Slide assembly as close to cone as possible (a.). With a pencil, outline assembly on mounting surface.

Installation

20.

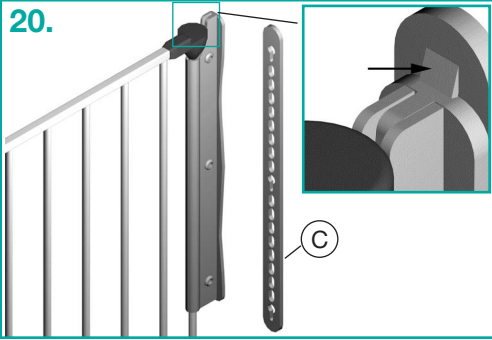

Remove wall plate (C) from assembly by pressing locking tab (a.) and lifting it off.

21.

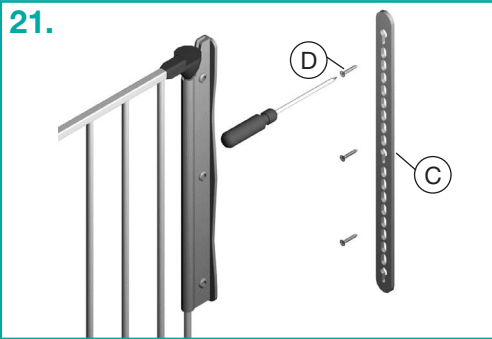

Note: Screws provided are for mounting directly into wood. If mounting into brick, drywall or other surfaces, use appropriate hardware.

Hold wall plate (C) inside the outline and screw in 3 wood screws (D). Space screws evenly. There are multiple holes in the wall plate giving many screw location options.

Reattach assembly to wall plate (see 16. a, b and c).

22.

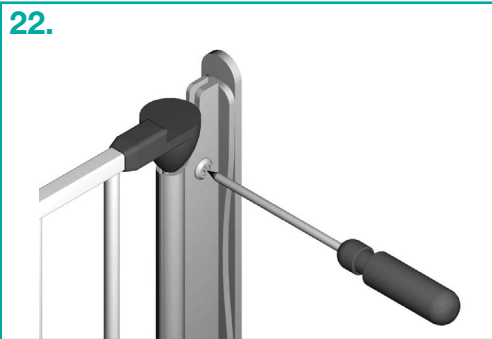

Tighten 3 sets of assembly screws and nuts.

23.

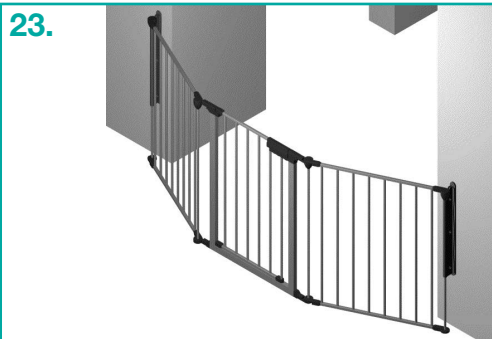

Now you are ready to mount other end of ConfigureGate™. Follow steps 12 to 22.

Operation

24.

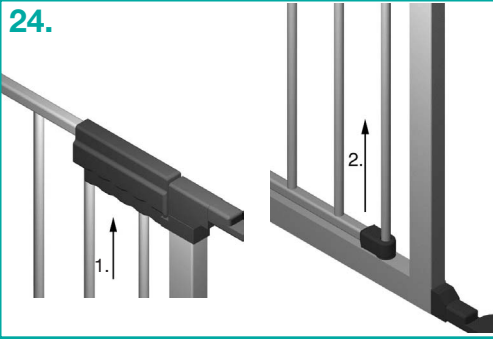

Opening the walk through door:

Squeeze handle up as much as possible (1). The locking bar should release from bottom frame (2). Door can now swing open in either direction.

25.

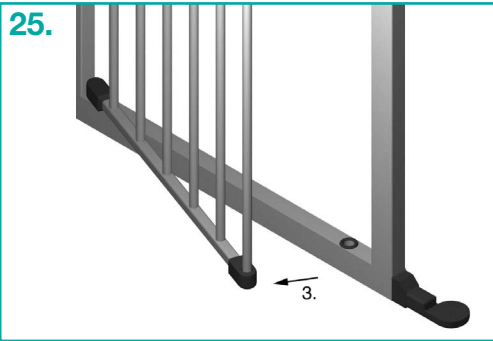

Closing and locking the walk through door:

While closing door, squeeze handle up as much as possible (24.1.) and align bottom of door with gate frame (24.2.). Release handle and door should lock. **Gate should always be in locked position.**

26.

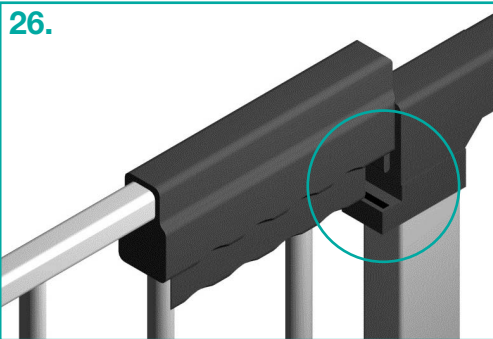

Door will be properly locked when handle hook and bottom locking bar have engaged. Test to ensure door is locked.

Gate Care

- No part of this gate requires lubrication.
- Clean using warm soapy water, or a damp cloth.
- Do not use abrasive cleaners or bleach.
- If using outdoors, and to help prevent rust, treat all exposed metal on the gate with a rust inhibitor. Some rusting may still occur.

